

Sinclair Collins® Global SC2100 Series

Stainless Steel, 460 PSI Process Control Valves



ENGINEERING YOUR SUCCESS.

Fluid Controls Global

In setting the standards in process control applications for over 80 years, our reputation has been built on having the strongest product features in the valve industry.

Designed for Durability

The unique design and reliable performance of the Global SC2100 Series Process Control Valves make them ideally suited for various process applications. These rugged cylinder-actuated stainless steel valves are designed for a bubble-tight seal. Their slimmer shape enables them to fit into applications where space is a consideration. Additional flexibility is provided by the choice of inline or flange mounting.

Wide Range of Industrial Application

Over the years, Sinclair Collins has served many industries in controlling the temperature and pressure of steam and water, as well as vacuum and oil. The new stainless steel valves allow Sinclair Collins to address even more demanding applications in the following industries:

- Tire Curing
- Chemical/Industrial Processing
- Food and Beverage
- Pulp and Paper Products
- Foundry Operations
- Automobile
- Textiles
- Petroleum
- Semi-Conductors

Quality from the start

The stainless steel investment cast components are machined in our dedicated lines, giving us 100% control of mechanical properties and the quality process. All of our other components must meet our high performance specifications and quality control standards.

After assembly, each valve is fully tested at rated pressure prior to shipment and all material and workmanship are covered by a One-year warranty.

Features

- Two and three-way operation.
- Cv = 3.7 to 23.5 (Port 1 to 2)
- Maximum operating pressure 460 PSI (32 Bar)
- 316/304 stainless steel body.
- Cylinder operator pressure range:
 37-51 PSI(2.5 to 3.5 Bar).
- Pilot port: PT 1/4"
- Stainless Steel cylinder cover for corrosion resistance providing longer piston seal life.
- Unique self-centering piston eliminates misalignment providing longer piston seal life.
- Actuator spring has high temperature coating for corrosion resistance.
- Inline or flange mounting. Flanges available in ANSI, DIN and JIS styles.
- Dual bearing guided stem.
- Stem seals are designed for high performance Utilizing spring loaded, Carbon filled PTFE materials.
- The 4 bolt bottom cap design allows for easier flange mounting (orientation) in port 3.
- Temperature range:
 -40 °F to 450 °F (-40 °C to 232 °C)

3-Way

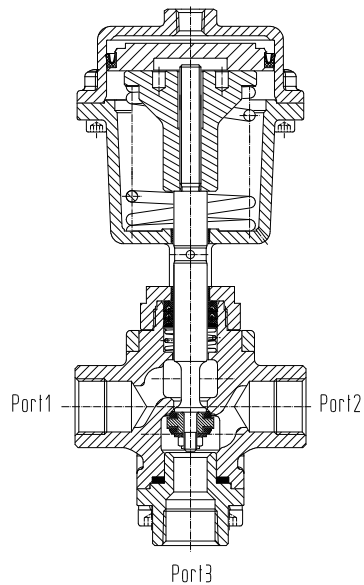

2-Way Normally Open

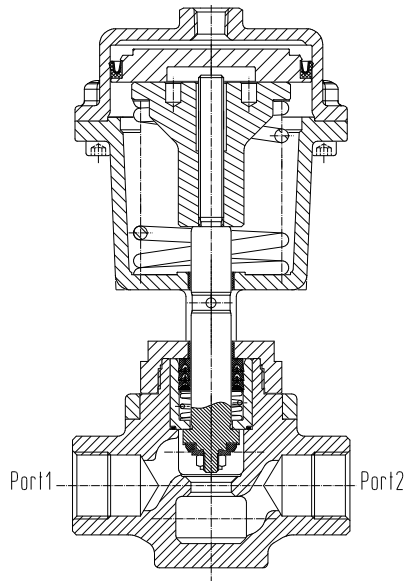

2-Way Normally Closed

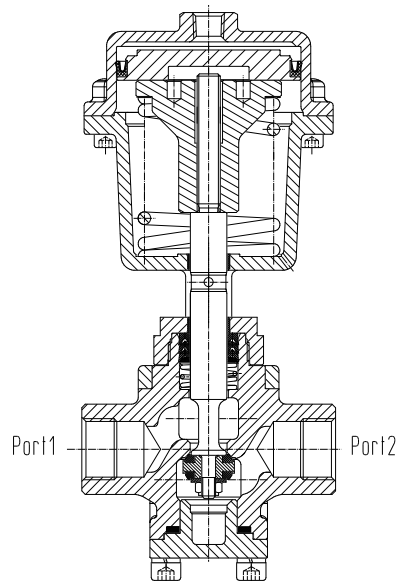

Features

**Global SC2100 Series
Process Control Valves**



Engineering Specifications

- **Sizes:** 1/2", 3/4", 1", 1-1/2"
- **Media:**
Steam, hot or cold water, air and inert gas.
- **Max. Operating Pressure:**
460 PSI (32 Bar)
- **Actuator Pressure Range:**
37-51 PSI (2.5-3.5 Bar)
- **Temperature Range:**
-40 °F to 450 °F (-40 °C to 232 °C)

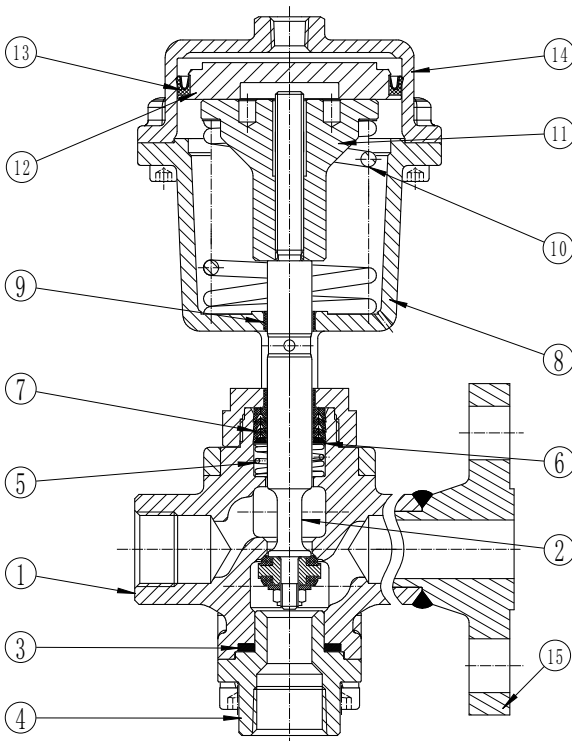

Item	Description	Standard Material
1	Body	316 stainless Steel
2	Stem	Stainless Steel
3	Gasket	304+Graphite
4	End Cap	316 Stainless Steel
5	Packer Spring	Stainless Steel
6	Packer Spreader	Brass
7	Packing	Virgin and Filled PTFE
8	Yoke	Ductile cast iron
9	Bearing	Engineered Plastics
10	Actuator Spring	Chrome-silicon SAE 9254
11	Spring Retainer	Aluminum
12	Piston	Anodized Aluminum
13	Piston Seal	Spring Energized PTFE Seal
14	Cover	Stainless Steel
15	Optional Integral Flange	316 stainless Steel

Flow Values

Size	Cv			
	Port 1 to 2	Port 2 to 1	Port 2 to 3	Port 3 to 2
1/2"	3.7	3.6	6.0	5.8
3/4"	5.7	5.4	9.5	9.6
1"	10.0	9.8	15.0	14.5
1½"	23.5	23.8	40.4	38.8

Piping Connections

Valve Type	Connection		
	Port 1	Port 2	Port 3
2-Way N.O.	Inlet	Outlet	—
2-Way N.C.	Inlet	Outlet	—
3-Way N.C.	Inlet	Outlet	Drain

Inline Mounted

- 2 - Way Normally Closed
- 3 - Way

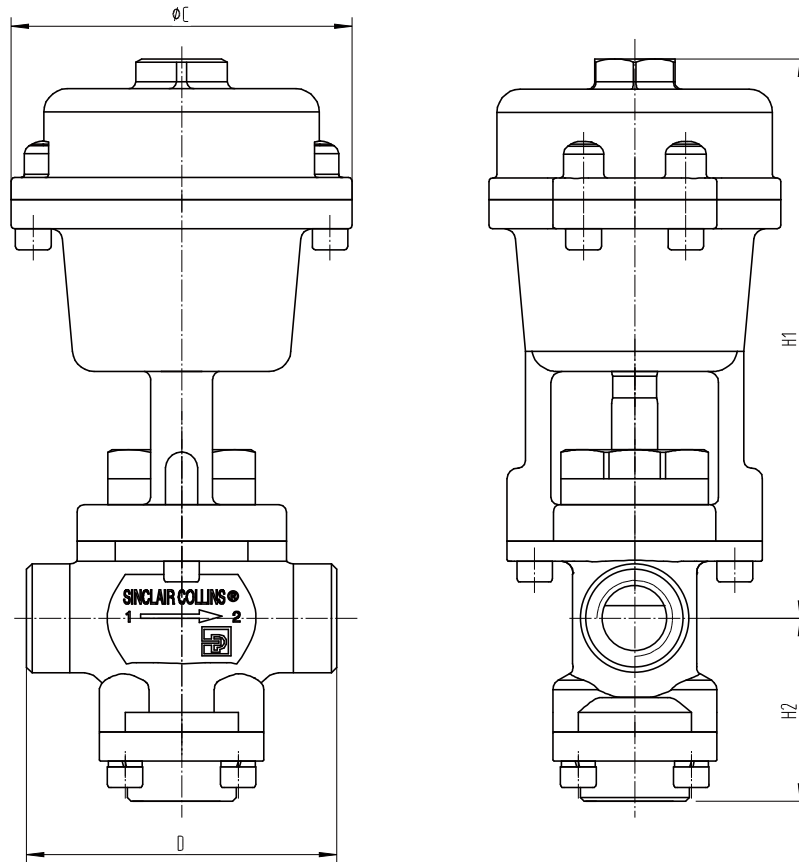

Port Size	Ø C (mm)	D (mm)	H1 (mm)	H2 (mm)		Weight (kg)	
				2 WAY NC	3 WAY NC	2 WAY NC	3 WAY NC
1/2"	93.5	85	153	47	50	2.55	2.55
3/4"	108	110	189	58	66	4.15	4.25
1"	124.5	120	230	70	71	6.15	6.2
1 1/2"	195	150	300	86	91	14.6	14.7

Features

Inline Mounted

2 - Way Normally Open

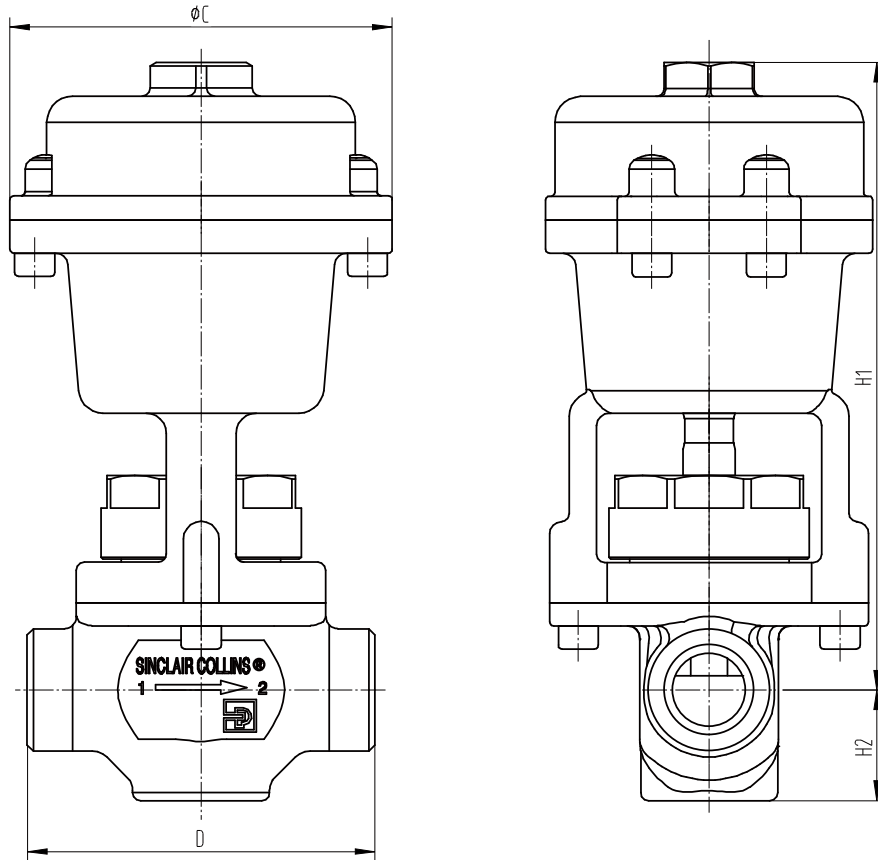

Port Size	Ø C (mm)	D (mm)	H1 (mm)	H2 (mm)	Weight (kg)
1/2"	93.5	85	153	28	2.45
3/4"	108	110	189	33	4
1"	124.5	120	230	36.5	5.85
1 1/2"	195	150	300	48.5	14.45

Flange Mounted

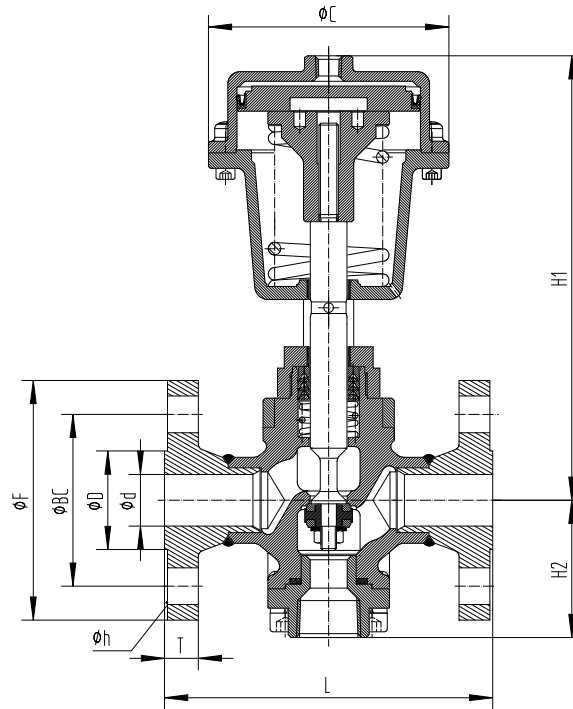

ANSI Flanges

Port Size	Ø C (mm)	Ø BC (mm)	Ø D (mm)	Ø d (mm)	Ø F (mm)	Ø h (mm)	H1 (mm)	H2 (mm)		L	T	f	Weight (kg)	
								2 WAY NC	3 WAY NC				2 WAY NC	3 WAY NC
1/2"	93.5	66.8	35	15.7	95.3	16	153	47	50	140	14.3	1.6	3.9	3.95
3/4"	108	82.6	43	20.8	117.6	19	189	58	66	150	16	1.6	6.45	6.55
1"	124.5	88.9	51	26.7	124	19	230	70	71	170	17.5	1.6	9	9.05
1 1/2"	195	114.3	73.1	40.9	156	22.3	300	86	91	200	20.7	1.6	19.65	19.75

JIS Flanges

Port Size	Ø C (mm)	Ø BC (mm)	Ø D (mm)	Ø d (mm)	Ø F (mm)	Ø h (mm)	H1 (mm)	H2 (mm)		L	T	f	Weight (kg)	
								2 WAY NC	3 WAY NC				2 WAY NC	3 WAY NC
1/2"	93.5	70	52	15	95	15	153	47	50	146	14	1	4.1	4.1
3/4"	108	75	58	20	100	15	189	58	66	146	16	1	5.85	5.95
1"	124.5	90	70	25	125	19	230	70	71	167	16	1	9	9.05
1 1/2"	195	105	85	40	140	19	300	86	91	190	18	2	18.25	18.35

DIN Flanges

Port Size	Ø C (mm)	Ø BC (mm)	Ø D (mm)	Ø d (mm)	Ø F (mm)	Ø h (mm)	H1 (mm)	H2 (mm)		L	T	f	Weight (kg)	
								2 WAY NC	3 WAY NC				2 WAY NC	3 WAY NC
1/2"	93.5	65	45	17.3	95	14	153	47	50	130	16	2	4	4
3/4"	108	75	58	22.3	105	14	189	58	66	150	18	2	6.15	6.25
1"	124.5	85	68	28.5	115	14	230	70	71	160	18	2	8.6	8.65
1 1/2"	195	110	88	43.1	150	18	300	86	91	200	18	3	18.65	18.75

Features

3-WAY FLANGE

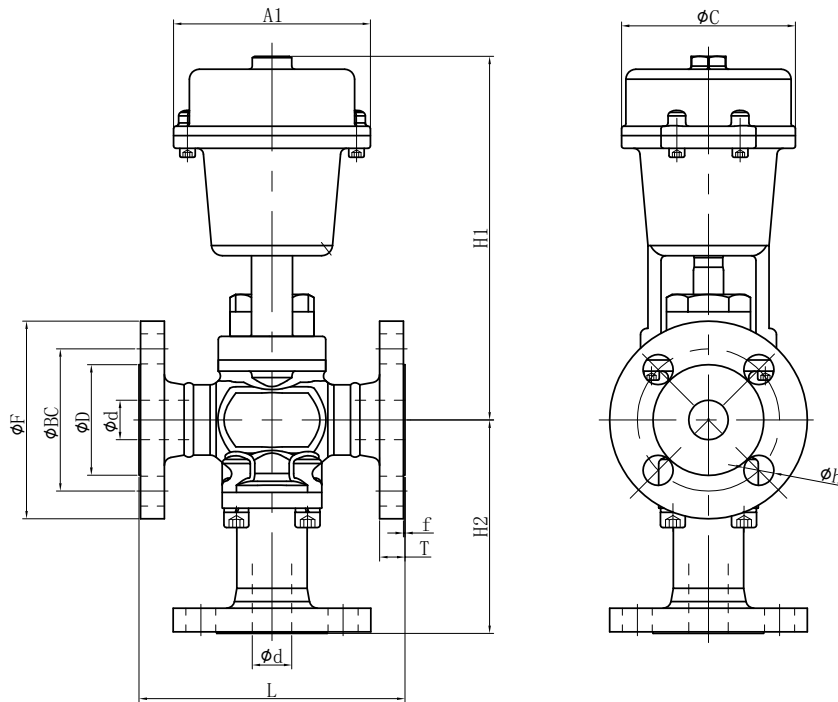

ANSI Flanges

Port Size	A1 (mm)	Ø C (mm)	Ø BC (mm)	Ø D (mm)	Ø d (mm)	Ø F (mm)	Ø h (mm)	H1 (mm)	H2 (mm)	L	T	f	Weight (kg)
1/2"	93.5	80	66.8	35	15.7	95.3	16	153	105	140	14.3	1.6	5.1
3/4"	108	95	82.6	43	20.8	117.6	19	189	110	150	16	1.6	8.5
1"	124.5	110	88.9	51	26.7	124	19	230	135	170	17.5	1.6	11.2
1 1/2"	195	170	114.3	73.1	40.9	156	22.3	300	150	200	20.7	1.6	23.1

JIS Flanges

Port Size	A1 (mm)	Ø C (mm)	Ø BC (mm)	Ø D (mm)	Ø d (mm)	Ø F (mm)	Ø h (mm)	H1 (mm)	H2 (mm)	L	T	f	Weight (kg)
1/2"	93.5	80	65	45	17.3	95	14	153	105	130	16	2	5.2
3/4"	108	95	75	58	22.3	105	14	189	110	150	18	2	8
1"	124.5	110	85	68	28.5	115	14	230	135	160	18	2	10.7
1 1/2"	195	170	110	88	43.1	150	18	300	150	200	18	3	22

DIN Flanges

Port Size	A1 (mm)	Ø C (mm)	Ø BC (mm)	Ø D (mm)	Ø d (mm)	Ø F (mm)	Ø h (mm)	H1 (mm)	H2 (mm)	L	T	f	Weight (kg)
1/2"	93.5	80	70	52	15	95	15	153	105	146	14	1	5.5
3/4"	108	95	75	58	20	100	15	189	110	146	16	1	7.5
1"	124.5	110	90	70	25	125	19	230	135	167	16	1	11
1 1/2"	195	170	105	85	40	140	19	300	150	190	18	2	21

GLOBAL SC2100 Numbering System

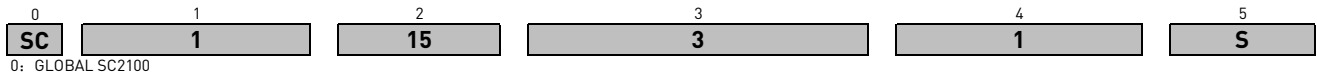

1: Actuator Size

1	Standard 2.5 - 3.5 Bar (37 - 51 PSI)
---	---

2: Port/Flange Size

08	DN08	1/4"
12	DN12	3/8"
15	DN15	1/2"
20	DN20	3/4"
25	DN25	1"
40	DN40	1-1/2"

3: Port Thread or Flange Style *

	Port 1&2	Port 3
0	NPTF Thread	NPTF Thread
1	BSPT Thread	BSPT Thread
3	ANSI Flange(300#)	NPTF
4	DIN Flange(PN40)	BSPT
5	JIS Flange(20K)	BSPT
6	ANSI Flange(300#)	ANSI Flange(300#)
7	DIN Flange(PN40)	DIN Flange(PN40)
8	JIS Flange(20K)	JIS Flange(20K)

4: Function

1	2-Way, Normally Closed
2	2-Way, Normally Open
3	3-Way, Normally Closed

5: Body Material

S	304 SS
R	316 SS

NOTES

* DN08 (1/4") and DN12 (3/8") threaded ports only. Consult factory for availability. Reference weights and dimensions for the DN 15 (1/2") models.

EXAMPLE : SC11531S

1/2" , 2-Way Normally Closed Valve with 304 Stainless Steel Body and ANSI Flange

Features

Repair Kit

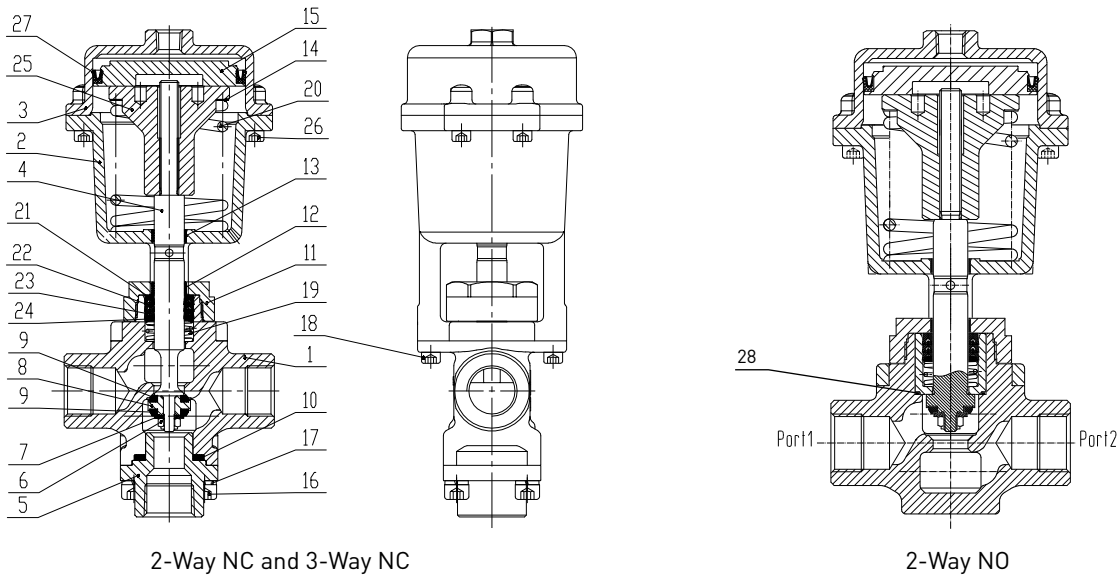

Repair Kit list

Part No.	Description
C301238	DN15 Repair kit (Size 1/2")
C301239	DN20 Repair kit (Size 3/4")
C301240	DN25 Repair kit (Size 1")
C301241	DN40 Repair kit (Size 1-1/2")

Repair kit includes below items

Item	Description	Qty	Standard Material
9	Disc ring	2	TFM with 20% Carbon
10	Gasket	1	304 + Graphite
12	Bearing	1	Engineering plastics
21	Seals Joint (Dust seal)	1	TFM with 20% Carbon
22	Packing I	1	Virgin TFM
23	Packing II	1	TFM with 20% Carbon
27	Piston seal	1	PTFE+AISI301
28	Seals Gasket	1	PTFE+AISI301

Setting the Standards for Control Valves in Industrial Processes

***Call for a free catalog on other
quality products from Sinclair Collins:***

- 200 PSI Valves for Steam, Hot or Cold Liquids
- 500 PSI Bronze Control Valves
- Modulating Control Valves
- 4000 & 6000 PSI High Pressure Service Control Valves
- Cold Service Control Valves for Raw Water, Oil, Water and Soluble Oil
- Two-Pressure Hydraulic Control Valves
- 3500 PSI Check Valve for Raw Water, Oil, Water and Soluble Oil



Parker Worldwide

AE – UAE, Dubai
Tel: +971 4 8127100
parker.me@parker.com

AR – Argentina, Buenos Aires
Tel: +54 3327 44 4129

AT – Austria, Wiener Neustadt
Tel: +43 (0)2622 23501-0
parker.austria@parker.com

AT – Eastern Europe, Wiener Neustadt
Tel: +43 (0)2622 23501 900
parker.easteurope@parker.com

AU – Australia, Castle Hill
Tel: +61 (0)2-9634 7777

AZ – Azerbaijan, Baku
Tel: +994 50 2233 458
parker.azerbaijan@parker.com

BE/LU – Belgium, Nivelles
Tel: +32 (0)67 280 900
parker.belgium@parker.com

BR – Brazil, Cachoeirinha RS
Tel: +55 51 3470 9144

BY – Belarus, Minsk
Tel: +375 17 209 9399
parker.belarus@parker.com

CA – Canada, Milton, Ontario
Tel: +1 905 693 3000

CH – Switzerland, Etoy
Tel: +41 (0)21 821 87 00
parker.switzerland@parker.com

CL – Chile, Santiago
Tel: +56 2 623 1216

CN – China, Shanghai
Tel: +86 21 2899 5000

CZ – Czech Republic, Klecany
Tel: +420 284 083 111
parker.czechrepublic@parker.com

DE – Germany, Kaarst
Tel: +49 (0)2131 4016 0
parker.germany@parker.com

DK – Denmark, Ballerup
Tel: +45 43 56 04 00
parker.denmark@parker.com

ES – Spain, Madrid
Tel: +34 902 330 001
parker.spain@parker.com

FI – Finland, Vantaa
Tel: +358 (0)20 753 2500
parker.finland@parker.com

FR – France, Contamine s/Arve
Tel: +33 (0)4 50 25 80 25
parker.france@parker.com

GR – Greece, Athens
Tel: +30 210 933 6450
parker.greece@parker.com

HK – Hong Kong
Tel: +852 2428 8008

HU – Hungary, Budapest
Tel: +36 1 220 4155
parker.hungary@parker.com

IE – Ireland, Dublin
Tel: +353 (0)1 466 6370
parker.ireland@parker.com

IN – India, Mumbai
Tel: +91 22 6513 7081-85

IT – Italy, Corsico (MI)
Tel: +39 02 45 19 21
parker.italy@parker.com

JP – Japan, Tokyo
Tel: +81 (0)3 6408 3901

KR – South Korea, Seoul
Tel: +82 2 559 0400

KZ – Kazakhstan, Almaty
Tel: +7 7272 505 800
parker.easteurope@parker.com

MX – Mexico, Apodaca
Tel: +52 81 8156 6000

MY – Malaysia, Shah Alam
Tel: +60 3 7849 0800

NL – The Netherlands, Oldenzaal
Tel: +31 (0)541 585 000
parker.nl@parker.com

NO – Norway, Asker
Tel: +47 66 75 34 00
parker.norway@parker.com

NZ – New Zealand, Mt Wellington
Tel: +64 9 574 1744

PL – Poland, Warsaw
Tel: +48 (0)22 573 24 00
parker.poland@parker.com

PT – Portugal, Leca da Palmeira
Tel: +351 22 999 7360
parker.portugal@parker.com

RO – Romania, Bucharest
Tel: +40 21 252 1382
parker.romania@parker.com

RU – Russia, Moscow
Tel: +7 495 645-2156
parker.russia@parker.com

SE – Sweden, Spånga
Tel: +46 (0)8 59 79 50 00
parker.sweden@parker.com

SG – Singapore
Tel: +65 6887 6300

SK – Slovakia, Banská Bystrica
Tel: +421 484 162 252
parker.slovakia@parker.com

SL – Slovenia, Novo Mesto
Tel: +386 7 337 6650
parker.slovenia@parker.com

TH – Thailand, Bangkok
Tel: +662 717 8140

TR – Turkey, Istanbul
Tel: +90 216 4997081
parker.turkey@parker.com

TW – Taiwan, Taipei
Tel: +886 2 2298 8987

UA – Ukraine, Kiev
Tel: +380 44 494 2731
parker.ukraine@parker.com

UK – United Kingdom, Warwick
Tel: +44 (0)1926 317 878
parker.uk@parker.com

US – USA, Cleveland
Tel: +1 216 896 3000

VE – Venezuela, Caracas
Tel: +58 212 238 5422

ZA – South Africa, Kempton Park
Tel: +27 (0)11 961 0700
parker.southafrica@parker.com

European Product Information Centre

Free phone: 00 800 27 27 5374
(from AT, BE, CH, CZ, DE, EE, ES, FI, FR, IE, IL, IS, IT, LU, MT, NL, NO, PT, SE, SK, UK)
www.parker.com

17-02-B AUTO-CH-12P-3559



Your local authorized Parker distributor